

Chemical Reactions: Introduction to Reaction Types

****Lab Notebook****

Record observations for **all** of the chemical reactions carried out during the lab in your lab book. These observations should include:

- observations of the reactant(s) before the reaction
- observations of the reaction mixture during the reaction
- observations of the product(s) after the reaction.

Your observations of a material should contain the color, clarity and state of matter, plus any useful descriptions of the material (for example, a sample of magnesium might be described as a smooth, shiny, silver, opaque solid).

Your observations of the reaction in progress should include anything of potential interest, such as “the color changed from green to blue”, “a pungent odor is present now”, “the test tube is getting warmer” or “bubbles are forming on the surface of the magnesium”.

Procedure:

Safety and waste disposal directions are listed with each procedure.

General Directions:

1. Carry out the reactions using the approximate quantities of reagents indicated. Unless otherwise stated, use test tubes. To estimate 2 mL, measure 2 mL of water in a graduated cylinder and pour it into a test tube. Save this test tube for comparison.
2. When combining solutions in a test tube, tap the tube a few times or use the Vortex mixer to ensure that the solutions have mixed completely.
3. To heat a solid in a test tube, position the test tube holder near the top of the test tube, and hold the test tube in a slanted position so that the opening of the test tube is pointed away from people. Keep the bottom of the test tube in the hottest part of the burner, but continuously move it back and forth over the flame to avoid “hot spots” (overheating one part of the test tube).
4. There are different concentrations of the HCl and NaOH used in this laboratory session. Check labels carefully for the proper chemical and concentration!

A. Acids and Bases.

CAUTION! NaOH and HCl can damage skin, eyes and clothing on contact. Rinse off any spills immediately with plenty of water for 10 minutes. In the event of a spill in the laboratory, notify your instructor immediately.

Place one piece each of red litmus paper and blue litmus paper on a watch glass, leaving a 1-inch space between them. Place a drop of 0.1 M HCl(aq) on each piece of litmus paper using a stirring rod and record your observations. Then place a drop of NaOH(aq) on each piece of litmus paper and record your observations. Place a drop of deionized water on each piece of litmus paper and record your observations.

	Red litmus paper	Blue litmus paper
Before reaction		
Reaction with HCl		
Reaction with NaOH		
Reaction with H ₂ O		

B. Combination Reactions

1. Heat a piece of copper wire strongly in the Bunsen burner flame (using crucible tongs) until a change in appearance is noted. Record any changes in the appearance of the copper wire in your lab report. Place the cooled wire in the regular trash.

CAUTION: Do not look directly at the Mg ribbon as it burns, or you may damage your eyes.

1. Hold a strip of magnesium ribbon in the burner flame (using crucible tongs).
2. Scrape the ash away from any **unreacted** Mg metal and place only the ash in a watch glass. Add a few drops of distilled H₂O. Carefully crush and stir the ash/water mixture with a stirring rod. Place one drop of the solution on blue litmus paper and another drop on red litmus paper.
3. Dispose of the wet ash and any unreacted Mg in the waste jar in the hood. Rinse off the pieces of litmus paper with water, then dispose of them in the regular trash.

	Copper Metal	Magnesium metal
Before heating		
During heating		
After heating		

	Red litmus	Blue litmus
Magnesium ash solution		

Make sure you conclude whether the ash is acidic or basic.

C. Decomposition Reactions

1. Place approximately half a spatula full (roughly pea-sized) of copper(II) carbonate in a dry test tube. **If you do not have a clean, dry test tube, ask your instructor for one. Do not try to dry a test tube during the laboratory period.** Observe the color of the sample. Using a test tube clamp, heat the test tube over a Bunsen burner until you notice a color change (approximately 30 seconds – 1 minute). Be sure to constantly move the test tube to avoid overheating the glassware! **Cool** the test tube in an **empty** beaker. Record the color of the solid sample after heating. When cool, dispose of the contents in the waste jar in the hood.

	Copper (II) carbonate
Before heating	
During heating	
After heating	

D. Single-Replacement Reactions

CAUTION: AgNO_3 will stain skin and clothes!

1. Place a piece of copper wire in a test tube with enough 0.1M AgNO_3 to cover it. Allow the test tube to stand for 5-10 minutes. Note changes in the appearance of both the wire and the solution. Dispose of the contents of the test tube in the waste jar in the hood.

	Copper Metal	AgNO_3 solution
Before reaction		
During reaction		
After reaction		

CAUTION: 3M $\text{HCl}(\text{aq})$ can damage skin and clothing on contact. Rinse any spills on skin immediately with plenty of water for 10 minutes. Neutralize all spills on the lab bench with water or NaHCO_3 solution, and rinse your hands thoroughly.

2. Place a small piece of zinc metal in a test tube containing 2 mL of 3M HCl , and record your observations. Dispose of the contents of the test tube in the waste jar in the hood.

	Zinc Metal	HCl solution
Before reaction		
During reaction		
After reaction		

E. Double Replacement/Precipitation Reactions

CAUTION: AgNO_3 will stain skin and clothing! Pb containing compounds are toxic and should not be ingested. HCl, HNO_3 and NaOH are corrosive and can cause chemical burns and damage clothing. Any hazardous chemical spilled on skin must be rinsed off with plenty of water for 10-15 minutes. If any spills occur in the laboratory, notify your instructor immediately.

You will obtain solutions of $\text{AgNO}_3(\text{aq})$, $\text{NaCl}(\text{aq})$, $\text{Ba}(\text{NO}_3)_2(\text{aq})$, $\text{HNO}_3(\text{aq})$ and $\text{Pb}(\text{NO}_3)_2(\text{aq})$. To EACH of them you will add solutions of $\text{NaNO}_3(\text{aq})$, $\text{NaCl}(\text{aq})$, $\text{Na}_2\text{SO}_4(\text{aq})$, $\text{NaOH}(\text{aq})$, $\text{Na}_2\text{CO}_3(\text{aq})$, and $\text{KI}(\text{aq})$.

First, record observations of each solution before the solutions are mixed.

You will mix the pairs of chemicals and observe the reactions between them, watching in particular for the appearance of a precipitate. All observations should be recorded in your data table in your notebook. If no change occurs, write "NR" for "No reaction". If a precipitate appears or if the solution changes in any other way, record your observations of the change.

Here is an example data table for different reagents. Your data table will be much larger (consider using the "landscape" orientation of the notebook, because this table will be wider than it is tall).

	$\text{KNO}_3(\text{aq})$	$\text{KI}(\text{aq})$	$\text{KOH}(\text{aq})$
$\text{CuCl}_2(\text{aq})$	NR	A brown, opaque solid is present in a clear, dark purple solution.	A translucent, blue gel-like ppt formed immediately.
$\text{Pb}(\text{NO}_3)_2(\text{aq})$	NR	An opaque yellow ppt formed in the clear colorless solution.	The solution turned cloudy white. Slowly a white opaque ppt settled in the clear, colorless solution.
$\text{KCl}(\text{aq})$	NR	NR	NR

Procedure

NOTE: All waste for this part of the experiment should be poured into the labeled waste containers in the hood and the test tubes rinsed with a minimum amount of water, which should also be placed into the waste container. DO NOT dispose of any solutions or solids down the drain.

1. Wash your well-plate thoroughly with soap and water, then rinse it completely with deionized water. A dirty well-plate can give incorrect results.
2. Place 5 drops of each aqueous solution in the correct wells based on the table you constructed for your observations.
3. For each of the following combinations, mix 10 drops of each solution in a clean test tube, so any reactions that take place can be observed on a larger scale:
 - $\text{Ba}(\text{NO}_3)_2(\text{aq})$ and $\text{NaOH}(\text{aq})$
 - $\text{HNO}_3(\text{aq})$ and $\text{NaOH}(\text{aq})$
 - $\text{HNO}_3(\text{aq})$ and $\text{Na}_2\text{CO}_3(\text{aq})$
4. Have your lab instructor sign off on your Double Replacement/Precipitation reaction observation table.
5. In the discussion section of your laboratory notebook, write a balanced chemical equation and clearly identify the solid product for any precipitation reactions that you observe.

F. Combustion Reaction

1. Place about 10-15 drops of 2-propanol (isopropyl alcohol, $\text{C}_3\text{H}_7\text{OH}$) in a small evaporating dish.
2. Ignite a wooden splint in the Bunsen burner and use the wooden splint to light the alcohol.

	2-propanol
Before ignition	
During combustion	
After combustion	

Chemical Reactions: Introduction to Reaction Types: Lab Report

Name: _____

Partner(s): _____

Section Number: _____

Word Equations and Balanced Chemical Equations

Translate each of the following word equations into a balanced chemical reactions by writing the correct chemical formulas (including physical states) for the reactants and products. Make sure to balance each equation.

Example: Aluminum metal reacts with oxygen to form solid aluminum oxide.

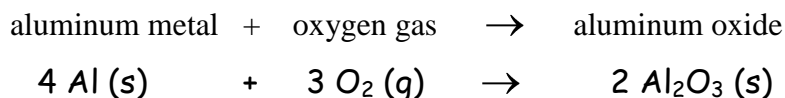

A. Combination Reactions

1. Copper reacts with oxygen to form copper(II) oxide.



2. Magnesium metal reacts with oxygen to form magnesium oxide.



3. Magnesium oxide (ash) reacts with water to form magnesium hydroxide.



B. Decomposition Reactions

1. Water decomposes into hydrogen gas and oxygen gas.



2. Copper(II) carbonate decomposes into copper(II) oxide and carbon dioxide gas.



C. Single-Replacement Reactions

1. Copper reacts with silver nitrate to form silver metal and copper(II) nitrate.

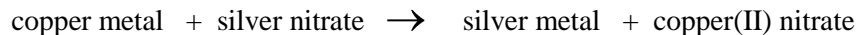

2. Zinc metal reacts with hydrochloric acid to produce zinc chloride and hydrogen.

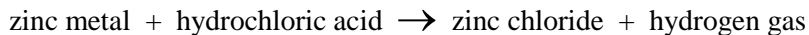

D. Double Replacement (precipitation) and Acid Base Reactions

Refer to your data table for the following selected sets of reactants and fill in the following blanks and beaker drawings. If there is no net ionic reaction because all the ions are spectators still complete the molecular reaction, the ionic reaction, and the beaker drawings, then put NR only for the net ionic reaction. An example **NOT** from this experiment is presented first.

Example: **calcium acetate and ammonium sulfate**

Reaction type: precipitation

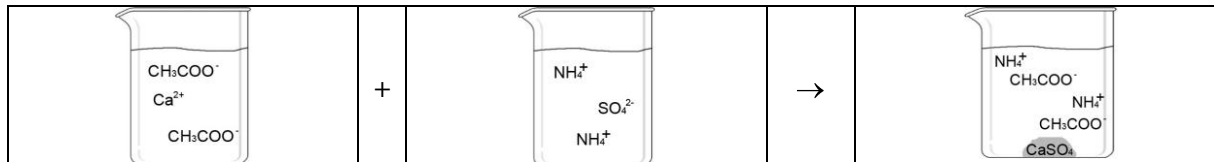
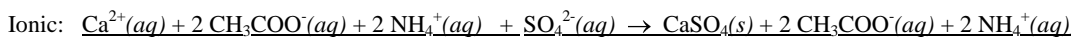

1. **lead (II) nitrate and potassium iodide**

Reaction type: _____

Molecular: _____

Ionic: _____

Net Ionic: _____

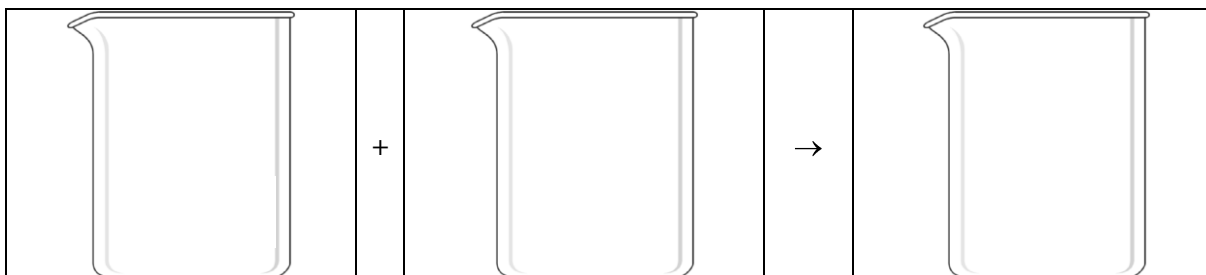

2. **nitric acid and sodium hydroxide**

Reaction type: _____

Molecular: _____

Ionic: _____

Net Ionic: _____

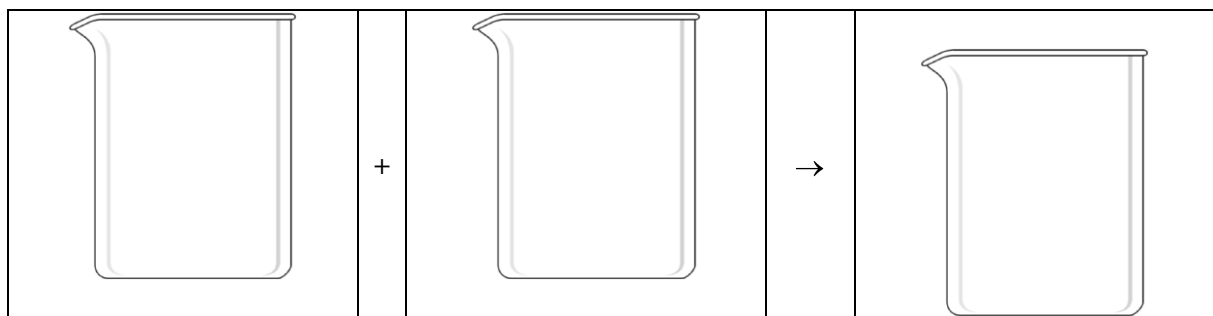

3. **barium nitrate and sodium sulfate**

Reaction type: _____

Molecular: _____

Ionic: _____

Net Ionic: _____

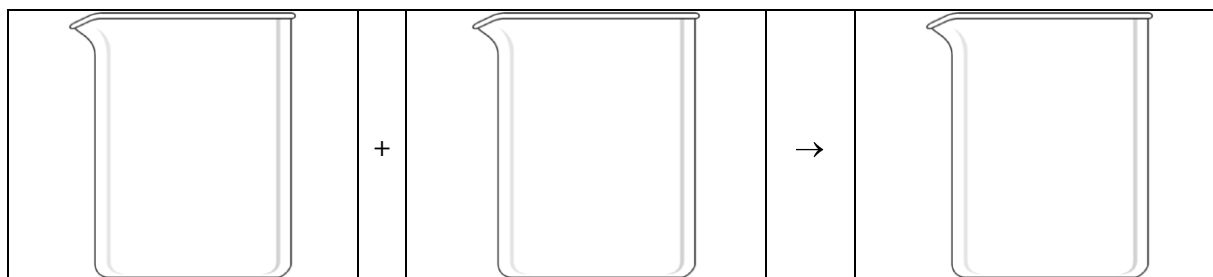

F. Combustion Reactions

1. Isopropyl alcohol burns in air to produce carbon dioxide and steam.

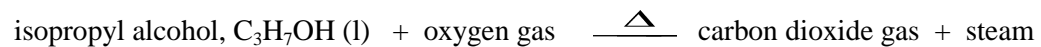

Balancing and Categorizing Chemical Equations:

Balance each of the 12 chemical equations given below, and identify each as one of the six types listed below.

Combination reaction (C)

Decomposition reaction (D)

Single-Replacement reaction (SR)

Double-Replacement/Precipitation reaction (DR)

Acid-Base Neutralization reaction (N)

Combustion reaction (B)

TYPE

